

---

# INSTALLATION INSTRUCTIONS

---

## ENERGY MANAGEMENT CONTROLLER

Model  
**CS2000A2**



Bard Manufacturing Company, Inc.  
Bryan, Ohio 43506  
*Since 1914...Moving ahead just as planned.*

Manual : 2100-478D  
Supersedes: 2100-478C  
File: Volume III Tab 19  
Date: 12-07-07

## Operation Overview

The CS2000A2 is an energy management controller that works in conjunction with a non-programmable HVAC (air conditioner or heat pump) thermostat to optimize energy savings and occupant comfort. The CS2000A2's learning capability, occupancy detection, and self-adjusting time-base provides effective control of HVAC systems without the need for user adjustments. There is no time clock to set or adjust as the controller automatically learns the occupancy pattern by observation and programs itself accordingly, and then automatically adapts to any schedule changes or unplanned occupancy. Simply stated, the CS2000A2 gives authority to the room thermostat in advance of learned first arrival to precondition the space and also during occupied periods. During unoccupied periods, the CS2000A2 monitors room temperature through its built-in thermistor and gives temporary authority back to the room thermostat long enough to maintain the selected set-back or set-up temperature condition selected within the CS2000A2. Additional control features of the CS2000A2 include the ability to operate ventilation and lighting of the same conditioned space.

### Model CS2000A2 General Specifications

#### Inputs/Outputs

Power Supply	10-30 VAC or VDC (<100ma)
HVAC Relay (pilot)	Form C, 24VAC, 3A Max.
HVAC Fan Relay (pilot)	Form C, 24VAC, 3A Max
Vent Relay (pilot)	Form B, 24VAC, 3A Max
Area Occupied Relay (pilot)	Form C, 24VAC, 3A Max

#### Installer Interface

Function Selection	10 PCIB DIP Switches
Temperature Set Points	10 PCIB DIP Switches
Indication	Single LED

#### Physical Characteristics

Operating Temperature	0 to 122F (-20 to 50C)
Case	2-piece, 4 x 5.375 x 2 in., high impact ABS, UL Listed
Color	White
Terminals	12-22 AWG, #3 screw
Mounting	4 screws

— Corner mounting bracket also supplied.

### Installation and Location Selection

One CS2000A2 is typically used to control a single HVAC unit conditioning a single space such as a classroom. The CS2000A2 should be mounted about 7' from the floor and centrally located on the wall such that it can "view" the largest central core area of the space. Judgment is required to select the most suitable location. For essentially square classrooms, a corner installations will provide maximum coverage of the typical classroom (See Fig. 1A). An angled corner mounting bracket is included to aid in corner installations. The bracket can be installed on either side of the CS2000A2 controller and is designed with an angle leg to fit into the corner to properly position the bracket. Fasten bracket to wall first, using field-supplied fasteners as desired, and then attach controller to bracket using supplied screws. See page 12 for more details. For rectangular spaces, the controller should be mounted directly to the wall, and positioned in the center of the short wall (See Fig. 1B). If possible, give consideration to where the instructor's desk will be, although this can change from room to room and is dependent upon each individuals preference.

**Coverage zone details on page 11.**

### Model CS2000A2 Features

Motion Sensor	Internal long-range PIR
Temperature Sensor	Internal thermistor
Learning	Daily and weekly schedule
Optimal; Start-Up	First morning wake-up
HVAC Systems	Air conditioners and heat pumps
Auxiliary Equipment Controlled	Lighting
Access Mode	Unlimited (motion sense only)
Setback Temperature Range	48 to 68F
Setup Temperature Range	78 to 90F
Demand Delay	Random time after start-up
Recovery Rates	Economy or comfort
Search Times	15, 30, 45 or 60 minutes (default 45)
Adaptive Freeze Protection	48 and 54F
Temperature Clamps	67 and 79F
Short Cycle Protection	3-minute off (minimum)
HVAC Problem Detection	Temperature threshold
Computer Watchdog Timer	Auto restart
HVAC High-Temperature Shutdown	122F
Manual Override	Resets after 24 hours
Power Fail Sense	Detects AC outage
Learned Schedule Retention	30 minutes minimum
Maid Control	2 <sup>nd</sup> set of temps for sleep

### Wiring Connections

All wiring to the CS2000A2 from the thermostat and HVAC system should be 18-gauge suitable for any applicable codes. See the appropriate connection diagrams for the HVAC equipment being controlled.

Vent, HVAC Fan, and Area Occupied control outputs are available in addition to the primary HVAC output used to enable the room thermostat. This can be used as shown or ignored based on the installation requirements.

Note 1: The HVAC Fan output must be used to assure continuous fan (blower) operation during the occupied periods (in case someone switches Fan switch on thermostat to "auto").

Note 2: If the Area Occupied output is to be used for lighting control a lighting control relay or contactor with NC (normally closed) contacts sized to the lighting load must be used as shown on the connection diagrams. The Area Occupied relay output on board the CS2000A2 is pilot duty only, and must be used to slave the field supplied lighting control device.

Note 3: PRECOND connections on CS2000A2 not used.

Note 4: MODE switch #3 should always be in the right-hand position.

Note 5: DOOR +/- connections are not used for actual door switch. Jumper across the +/- terminals enables 45 and 60-minute search time periods. See "Search Time" under Function Switch Settings on Page 3.

## FUNCTION SWITCH SETTINGS

The CS2000A2 Energy Monitor Controller operation is governed by the settings of the 10 function switches as shown below:

1. Learn (LRN)                    **Left = Anticipate (Factory default setting).** CS2000A2 learns occupancy schedule for each day of week  
**Right = Non-Anticipate.** CS2000A2 operates on occupancy only.
  
2. Pre-Purge (PRE P)        **Left = Activate Vent and HVAC Fan output upon first arrival (Factory default setting).**  
**Right = Pre-purge for 1 hour.** Vent and HVAC Fan outputs are turned "On" for 1 hour in advance of learned arrival time.
  
3. Mode                            **Left = DO NOT USE.**  
**Right = Unlimited (Factory default setting).** Control is based upon motion sense only.
  
4. Rate                            **Left = Economy.** Maximum energy savings, no wait after recovery before returning to setback/setup settings if occupancy doesn't occur on schedule, lower heat strip usage.  
**Right = Comfort. (Factory default setting).** Maximum comfort level, 30-minute wait after recovery before returning to setback/setup settings if occupancy doesn't occur on schedule, higher heat strip usage.
  
5. Search Time                Two factors affect the timing sequence:
  1. Position of Time Switch #5
  2. With or without jumper across Door +/- terminals

Time Switch Position	Door Jumper	Time Minutes
Left	No	15
Right	No	30
<b>Left</b>	<b>Yes</b>	<b>45 (Default)</b>
Right	Yes	60
  
6. N/C                            **Left = Do not use.**  
**Right = Required setting (Factory default setting).**
  
7. Stage                         **Left = HVAC (Thermostat) control (Factory default setting).**  
**Right = Do not use.**
  
8. Aux                            **Left = Area occupied output—used for lighting control (Factory default setting).**  
**Right = Do not use.**
  
9. DMD 2                        **Left = 100% duty cycle (Factory default setting).**  
**Right = Do not use.**
  
10. DMD 1                      **Left = 100% duty cycle (Factory default setting).**  
**Right = 80% duty cycle 15 minutes "On", 4 minutes "Off".**

## FUNCTION SWITCH SETTINGS

**Basic Temperature Settings.** Setting of the temperature switches determines the set-up and set-back temperatures that the CS2000A2 controls to during unoccupied periods. A minimum of two (2) switches must be "On" ----- one for set-up and one for set-back. Factory default settings are 84 and 62F, and offer a reasonable compromise between energy savings and comfort.

**Adaptive Freeze Protection.** Adaptive freeze protection functions automatically if either the 54F or 48F settings are selected for set-back. This feature checks for excessive heat loss during very cold outdoor conditions by measuring the rate at which the temperature falls during the HVAC unit's off cycle.

Excessive heat loss triggers the CS2000A2 to temporarily select the next higher setback temperature (up to 58F). This feature protects piping from freezing in excessively cold weather. The set-back control automatically returns to the selected value when the rate of fall returns to normal.

**Temperature Clamp.** The CS2000A2 employs temperature-limiting logic that prevents wasteful energy use and mis-operation of the HVAC equipment. This waste occurs when personnel set the room thermostat too hot in winter or too cold in summer. The temperature clamp feature operates only when the area is occupied and the room temperature exceeds 79F in winter or falls below 67F in summer. Under normal circumstances the limit action never engages.

Temperature clamp is automatic and not switch selectable. CS2000A2's software automatically determines the climatic season during unoccupied periods by measuring the room temperature fall or rise. This measurement occurs whenever the CS2000A2 turns off the HVAC unit. The season test determines whether the upper or lower clamp functions, and cancels the function when season determination may be uncertain which can occur during mild weather conditions. Room temperatures above 79F or below 67F enable the limit action. When the limit operates the HVAC unit operation stops, allowing the room temperature to drift freely. The CS2000A2 calculates the direction and magnitude of the drift and verifies the season. The temperature limit remains in effect once the proper season is confirmed.

### Function and Temperature Switches Map

RECOMMENDED SWITCH SETTINGS SHOWN BELOW

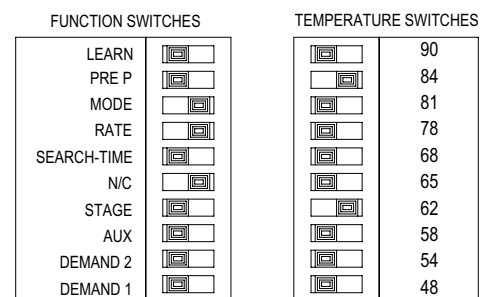

MIS-2064 A

Shaded Positions Are Factory Defaults

### Learning Schedule

The CS2000A2 has an enhanced learning program that works as follows:

1. There is no time clock to set or day of the week to adjust as the CS2000A2 learns by observation of actual events, and an internal timer keeps track of time on a 24-hour basis.
2. Learning starts to occur after initial installation and checkout, and after there has been a minimum of 7 hours unoccupied period registered.
3. The next morning arrival time is recorded as Day 1, and the following 6 days are established to have the same arrival time as Day 1. This is called "morning synchronization".
4. Day 2 will start to precondition based upon the amount of time it took for Day 1 to recover from the set-back or set-up condition the CS2000A2 has been configured for, and then will begin to adjust automatically if actual recovery times start to change.
5. Days 3 to 7 will follow the same strategy as Day 2.
6. Whenever the unoccupied days of the weekend occur during the first week of operation, there will be recovery in anticipation of arrival. When no one arrives within the selected search time of the anticipated schedule the CS2000A2 will shift to unoccupied status and wait until the next day.
7. Days 8 to 14 fine-tune the occupancy pattern by averaging Day 1 to Day 8, Day 2 to Day 9, etc.
8. For the unoccupied weekend days after 2 weeks of no one arriving, the CS2000A2 logic will determine those are the weekend days and will stay in set-back or set-up condition throughout the entire period.
9. Sensing the room being occupied and enabling the room thermostat to take command and condition the room accordingly accommodates irregular or unplanned events such as a parent-teacher conference in the evening or other special meetings, or an occasional weekend work session by the teacher. After occupants depart and the search time lapses, the CS2000A2 places the HVAC system back into unoccupied mode.
10. Should an evening or weekend occasion turn into a regularly scheduled event that occurs weekly, after the 2-week learning period, the CS2000A2 will add it to the schedule and operating routine. If any of those usage patterns then change and no one arrives, the CS2000A2 will go to unoccupied status after the selected search time of the learned arrival pattern, and after 2 weeks of seeing the same pattern will eliminate it from the schedule.
11. Holidays, weather delays, and other activities such as field trips that cause the classroom to be empty will cause the CS2000A2 to switch to unoccupied status after the selected search time after scheduled first arrival for that day. Should classroom become occupied later on the CS2000A2 restores authority to the wall thermostat for occupied control.

12. When extended periods of non-activity occur such as long holiday breaks or summer recess, the CS2000A2 uses the logic as explained above to place the HVAC systems in continuous set-back/set-up mode, and then responds and quickly relearns the usage pattern as it happens.

### Testing and Operating Hints

1. Red LED indicator gives helpful status information:
  - a. Lights momentarily after motion detection (sample rate is every 3 seconds)
  - b. Improper temperature switch settings - continuous "slow flash"
  - c. Manual override - "fast flashes"
  - d. Incorrect switch 3 (mode) setting - continuous "On"
  - e. Out-of-range temperature - continuous "On"
2. Check placement of controller by walking around in the classroom to determine occupancy indicator (red LED) lights up in the majority of the classroom.
3. Reposition if necessary. CS2000A2 has approximately a 25° parabolic view from centerline (can sense a 3-foot tall person @ 7 feet away from CS2000A2 when positioned 7 feet above the floor. See pages 11 & 12.
4. A 1-hour set-up/set-back operation for testing is allowed after power-up. Normal operation begins only after morning synchronization.
5. CS2000A2 has power backup circuit that will retain learned program for 30 minutes during power loss. After 30 minutes, controller must relearn schedule.
6. Manual override has 24-hour operation before automatic reset.

Lockout timer circuit inhibits HVAC operation for 3 minutes if 24V power to CS2000A2 is interrupted (requires 3 minutes for HVAC output to be switched after power up).

### Troubleshooting Hints

1. Night set-back/set-up may not engage during mild weather.
2. CS2000A2 and wall thermostat must be installed in the space that is being controlled.
3. Temperature clamp may infrequently inhibit operation while performing season check.
4. CS2000A2's motion sensor "field of view" must cover the key occupancy/traffic pattern.
5. Inverted CS2000A2 case cover blocks motion sensor view. Note: this is sometimes inverted intentionally for test purposes ---- be sure not to damage or mis-align the LED.

# WIRING DIAGRAM 1 AIR CONDITIONER CONNECTION

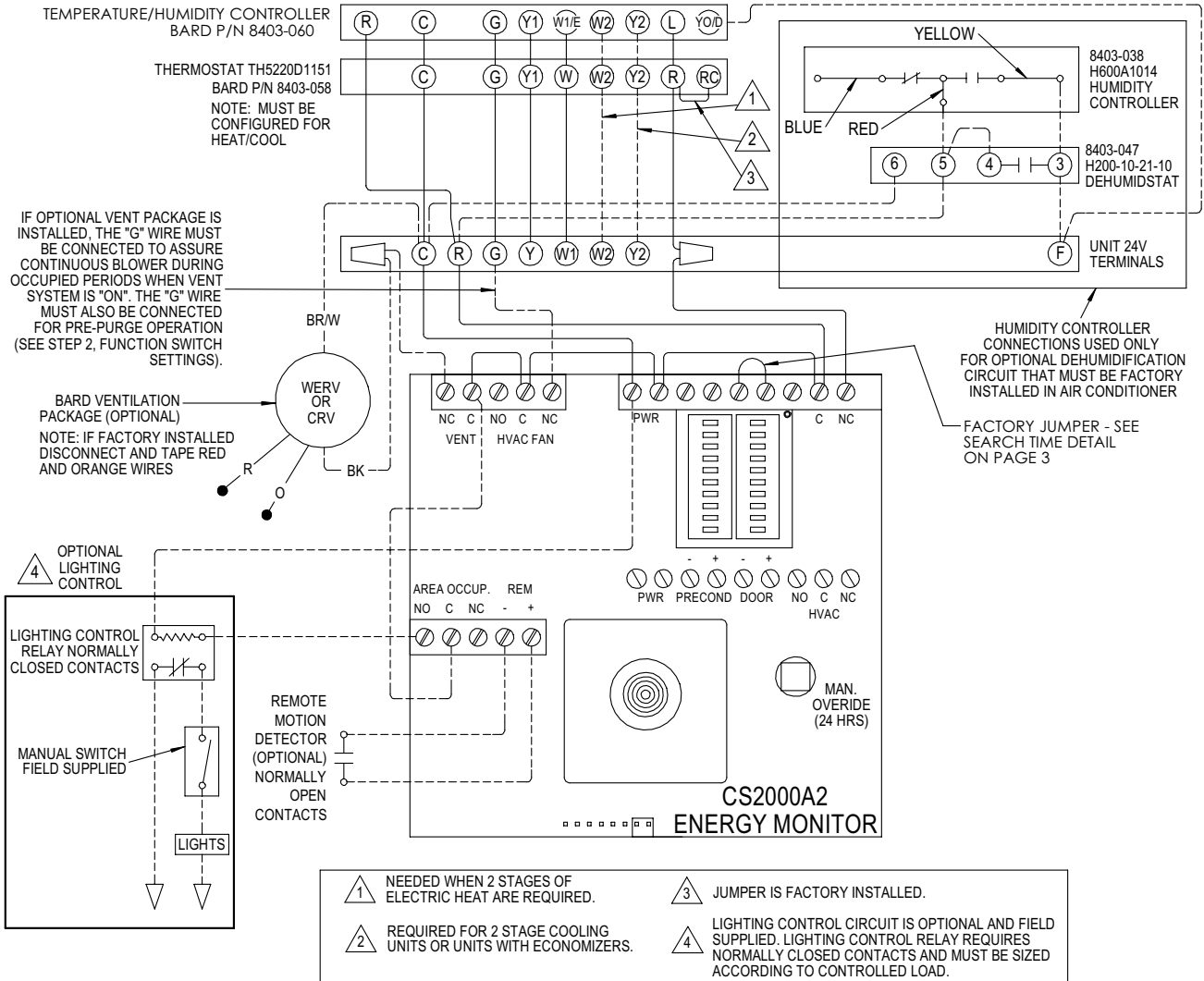

## RECOMMENDED SWITCH SETTINGS SHOWN BELOW

FUNCTION SWITCHES	TEMPERATURE SWITCHES
LEARN	90
PRE P	84
MODE	81
RATE	78
SEARCH-TIME	68
N/C	65
STAGE	62
AUX	58
DEMAND 2	54
DEMAND 1	48

4093-139 I

## WIRING DIAGRAM 2 WH, SH HEAT PUMP CONNECTION

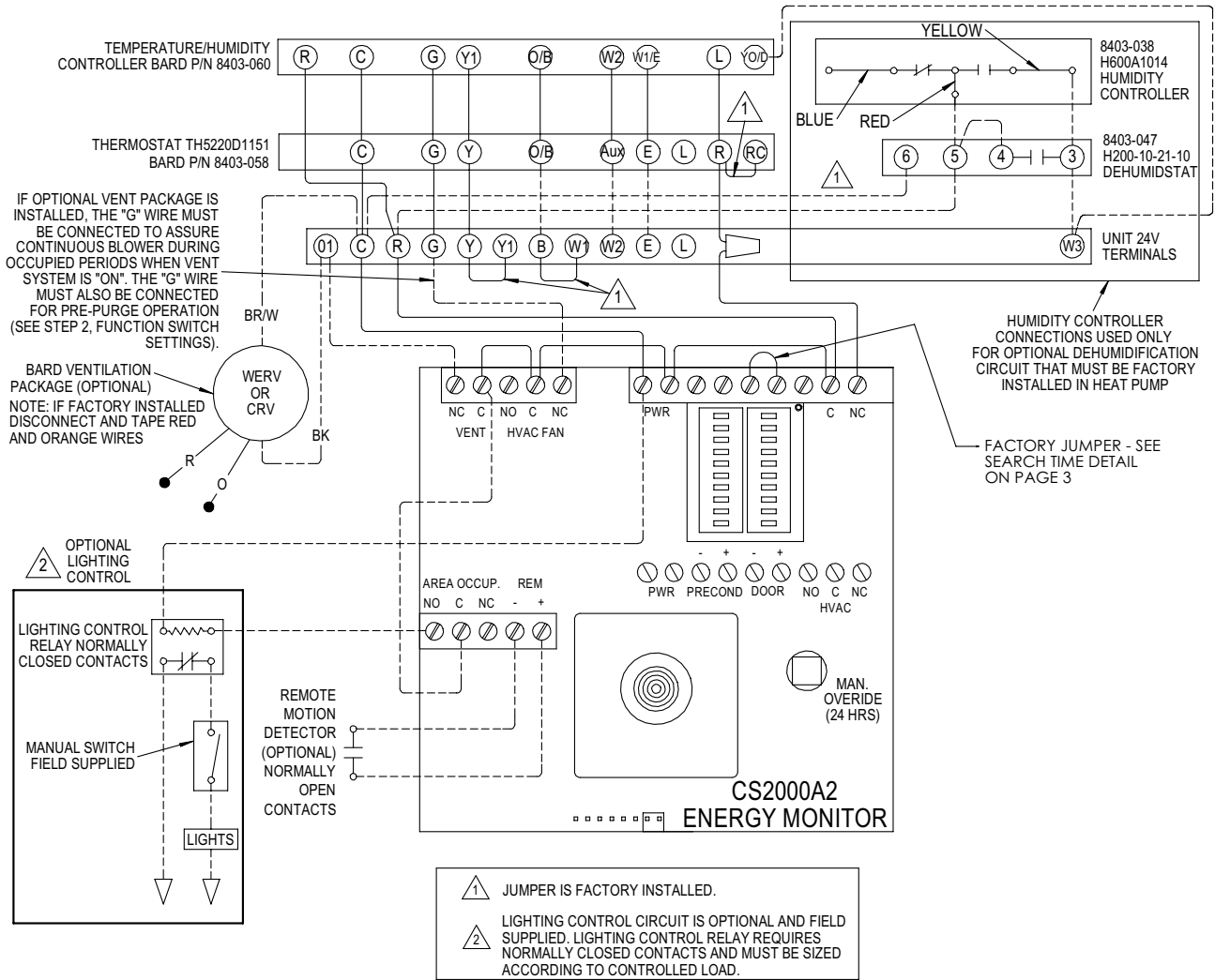

### RECOMMENDED SWITCH SETTINGS SHOWN BELOW

FUNCTION SWITCHES		TEMPERATURE SWITCHES	
LEARN			90
PRE P			84
MODE			81
RATE			78
SEARCH-TIME			68
N/C			65
STAGE			62
AUX			58
DEMAND 2			54
DEMAND 1			48

4093-140 J

**WIRING DIAGRAM 3**  
**QA, QH, QW SERIES CONNECTION**  
**FOR USE WITH "A" OR "G" CLIMATE CONTROL OPTION**

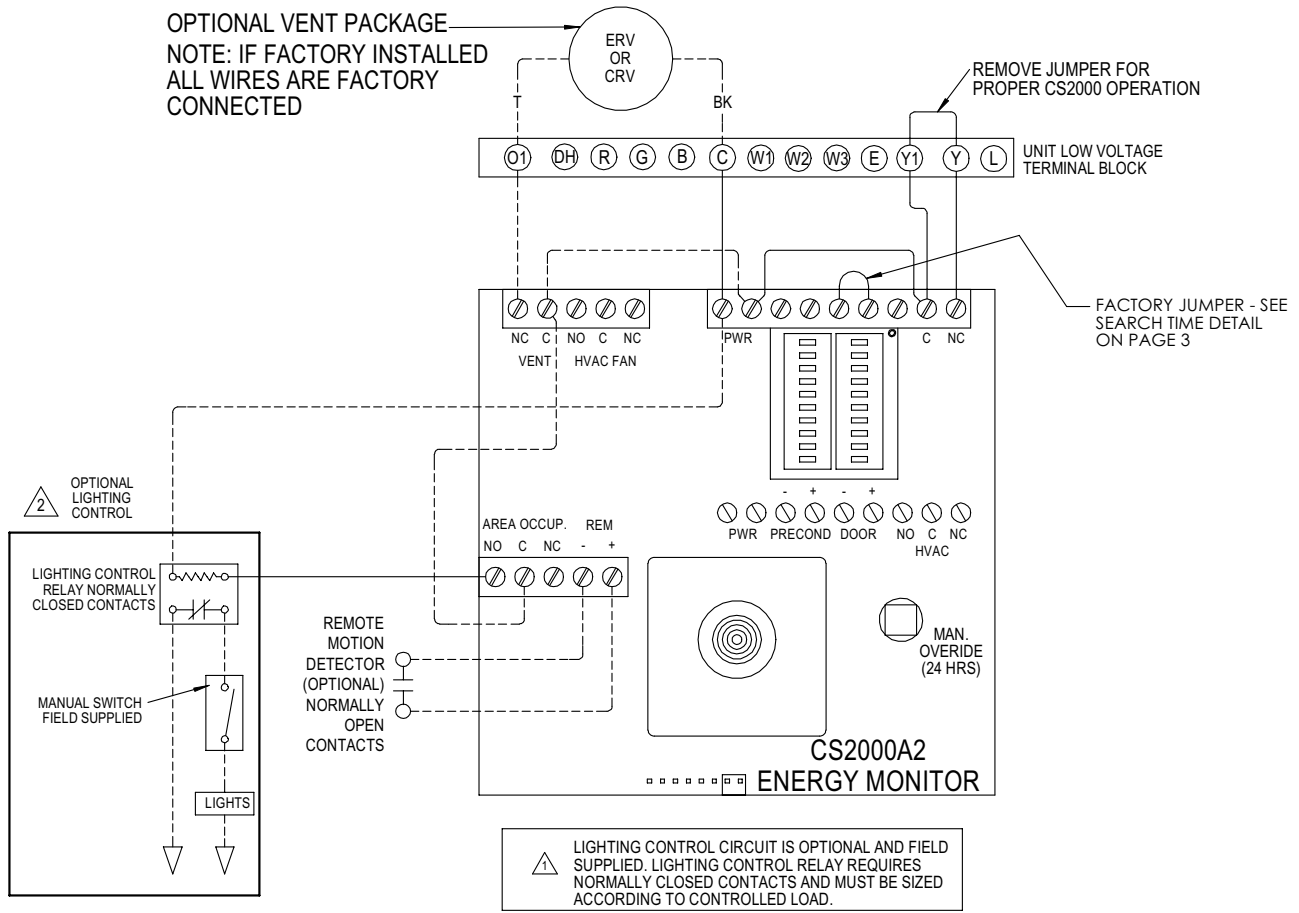

**RECOMMENDED SWITCH SETTINGS SHOWN BELOW**

FUNCTION SWITCHES		TEMPERATURE SWITCHES	
LEARN			90
PRE P			84
MODE			81
RATE			78
SEARCH-TIME			68
N/C			65
STAGE			62
AUX			58
DEMAND 2			54
DEMAND 1			48

4093-141 H

## WIRING DIAGRAM 4 QH, QW SERIES HEAT PUMP CONNECTION FOR USE WITH "X" CLIMATE CONTROL OPTION

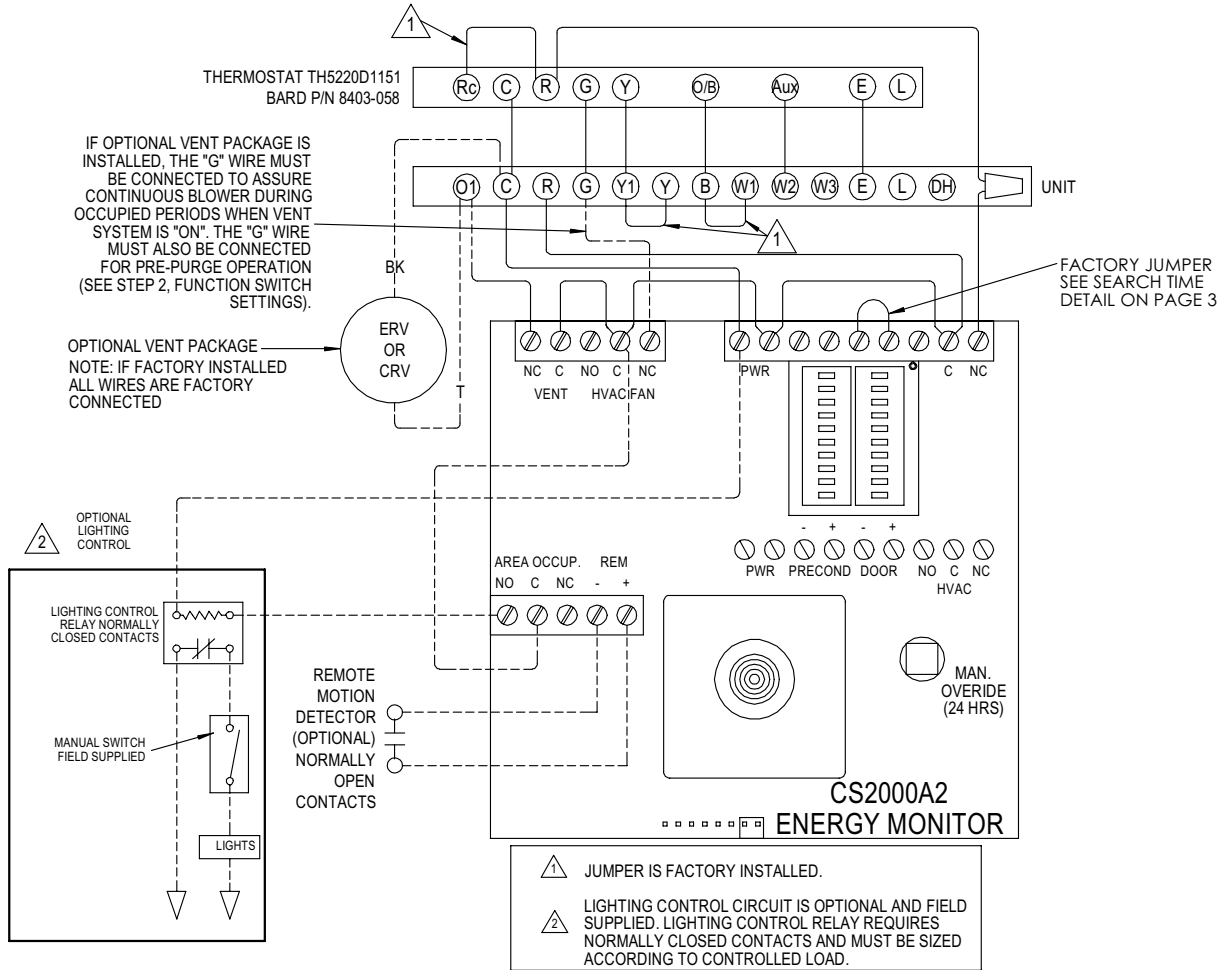

### RECOMMENDED SWITCH SETTINGS SHOWN BELOW

FUNCTION SWITCHES		TEMPERATURE SWITCHES	
LEARN			90
PRE P			84
MODE			81
RATE			78
SEARCH-TIME			68
N/C			65
STAGE			62
AUX			58
DEMAND 2			54
DEMAND 1			48

4093-142 H



## WIRING DIAGRAM 5 QA SERIES AIR CONDITIONER CONNECTION FOR USE WITH "X" CLIMATE CONTROL OPTION

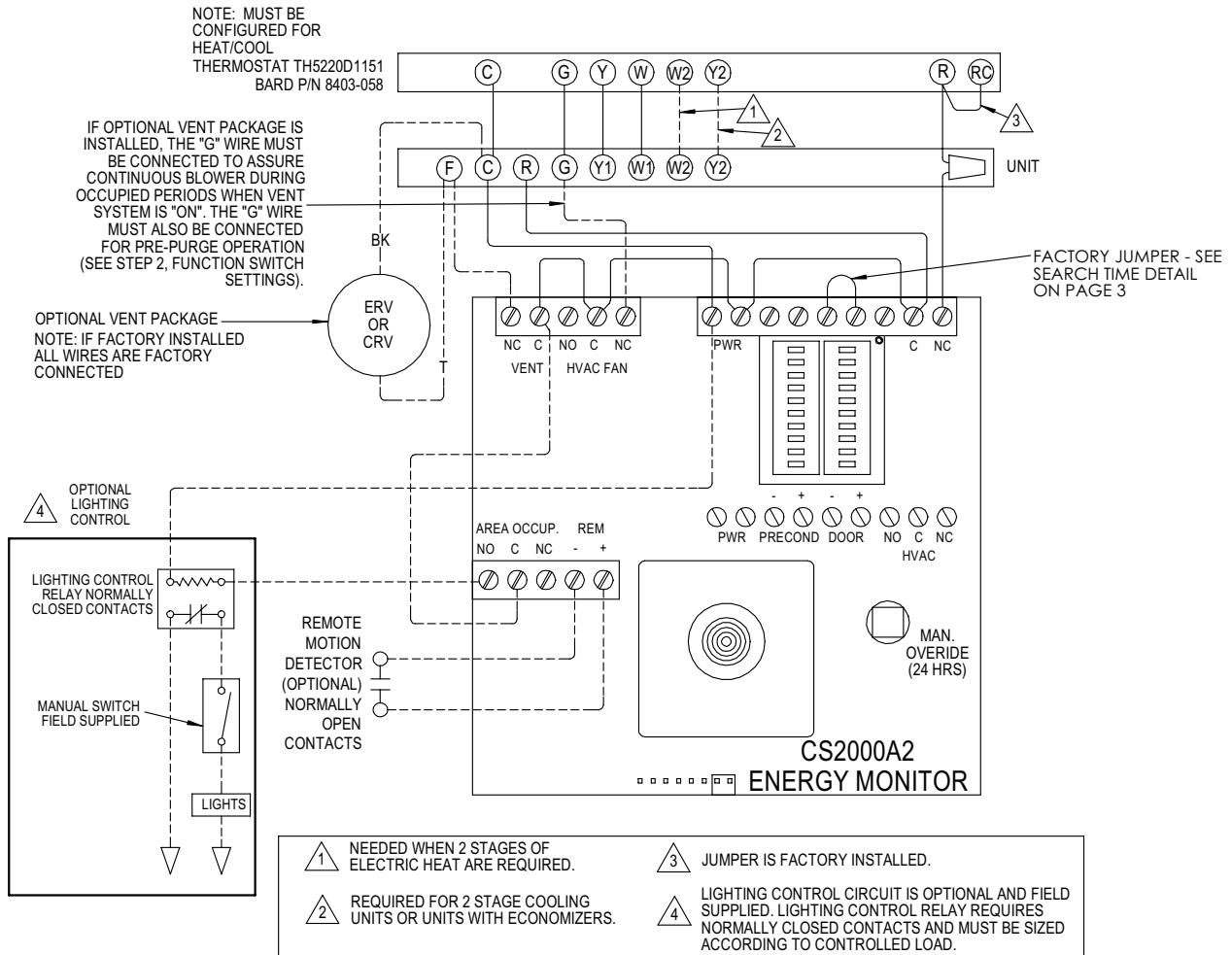

### RECOMMENDED SWITCH SETTINGS SHOWN BELOW

FUNCTION SWITCHES		TEMPERATURE SWITCHES	
LEARN			90
PRE P			84
MODE			81
RATE			78
SEARCH-TIME			68
N/C			65
STAGE			62
AUX			58
DEMAND 2			54
DEMAND 1			48

## WIRING DIAGRAM 6 WG SERIES GAS ELECTRIC CONNECTION DIAGRAM

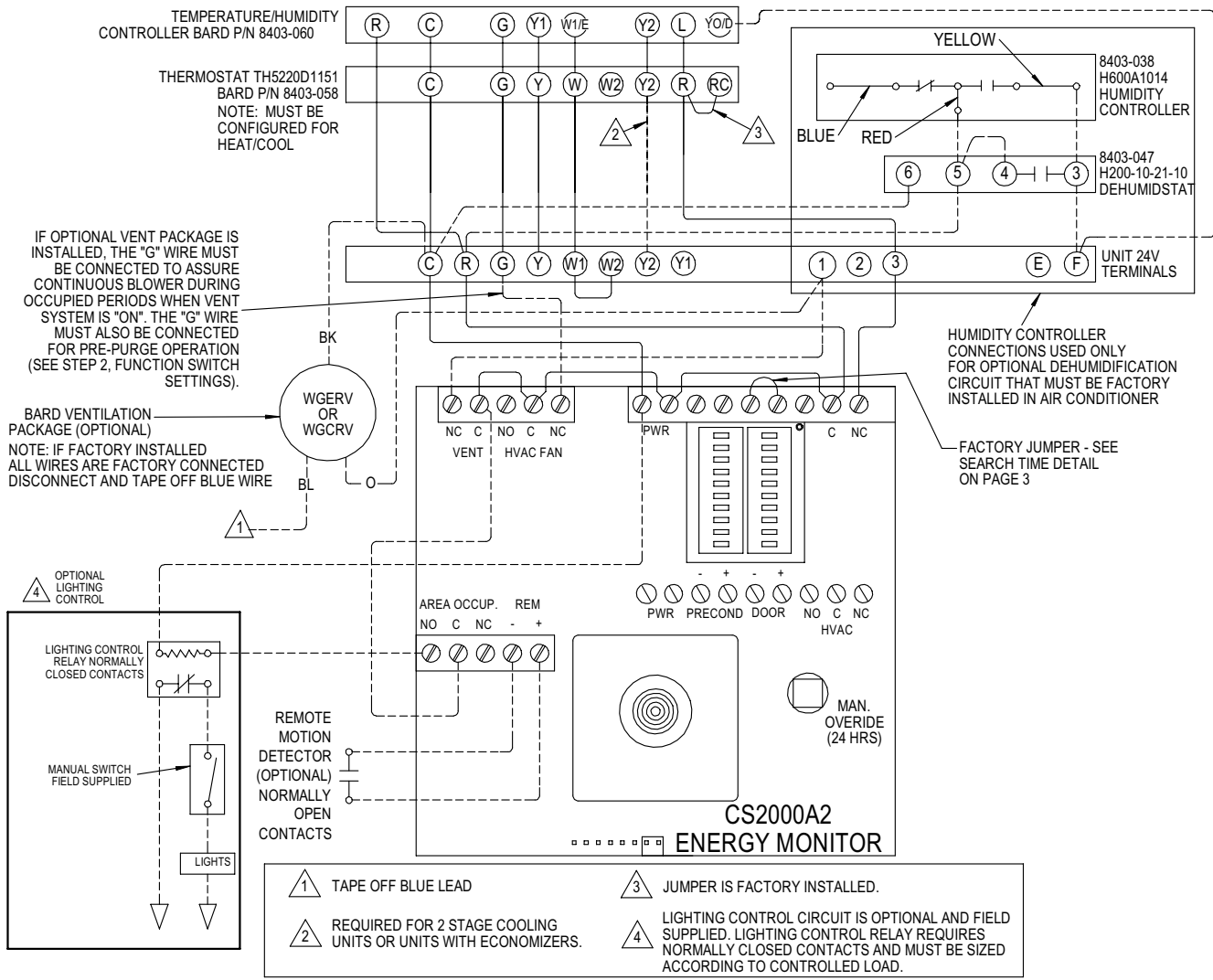

### RECOMMENDED SWITCH SETTINGS SHOWN BELOW







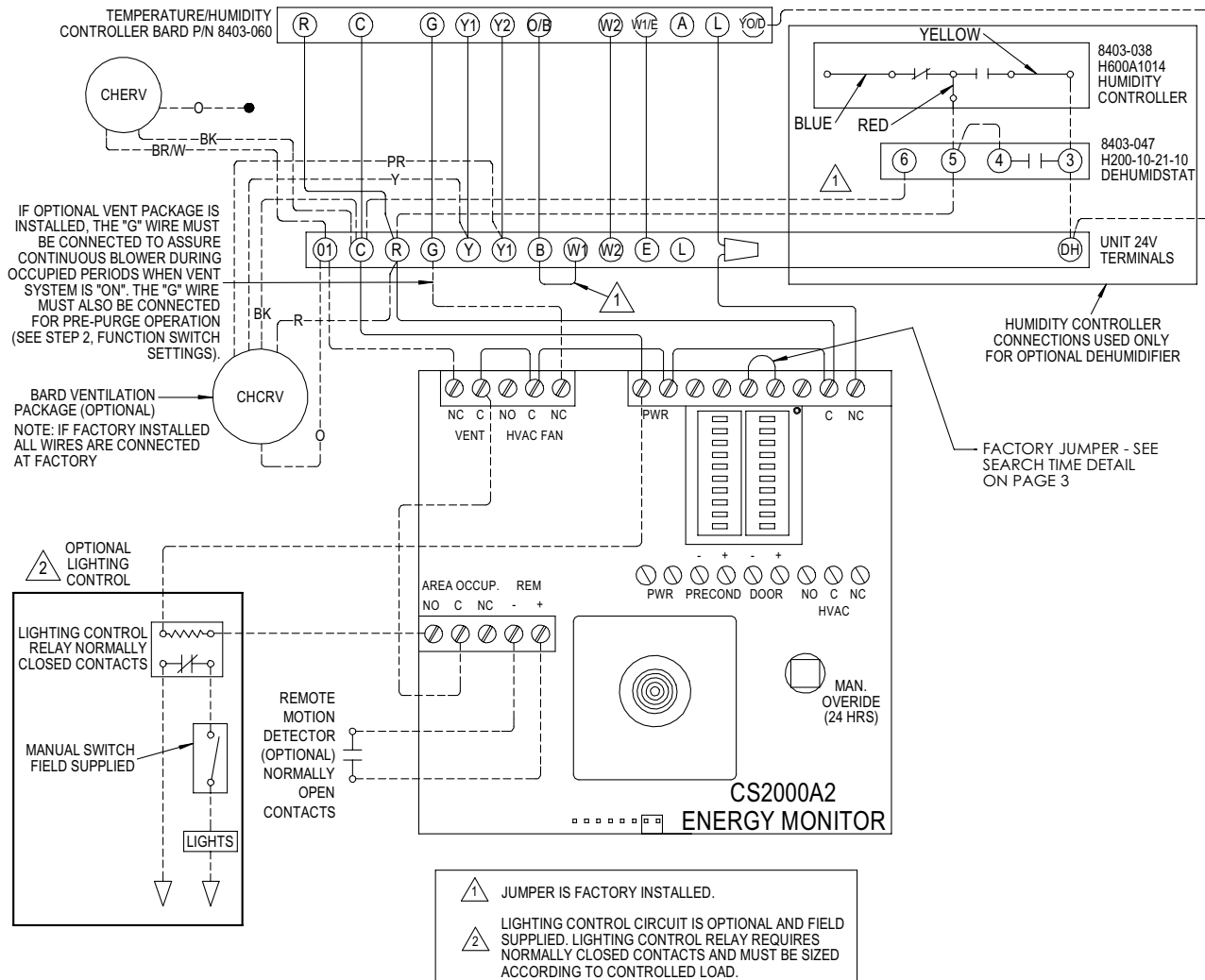













FUNCTION SWITCHES	
LEARN	
PRE P	
MODE	
RATE	
SEARCH-TIME	
N/C	
STAGE	
AUX	
DEMAND 2	
DEMAND 1	

TEMPERATURE SWITCHES	
	90
	84
	81
	78
	68
	65
	62
	58
	54
	48

## WIRING DIAGRAM 7 CH HEAT PUMP CONNECTION



### RECOMMENDED SWITCH SETTINGS SHOWN BELOW

FUNCTION SWITCHES	TEMPERATURE SWITCHES
LEARN 	 90
PRE P 	 84
MODE 	 81
RATE 	 78
SEARCH-TIME 	 68
N/C 	 65
STAGE 	 62
AUX 	 58
DEMAND 2 	 54
DEMAND 1 	 48

4093-148

## COVERAGE AREAS OF CS2000A2

**FIG. 1A**

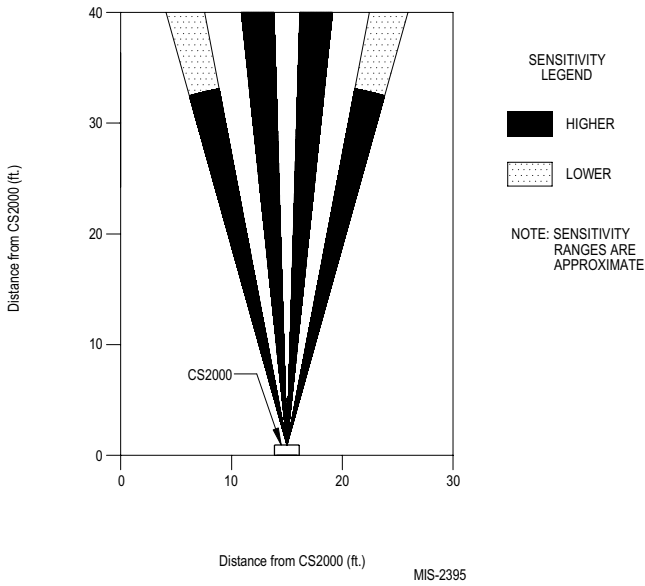

**FIG. 1B**

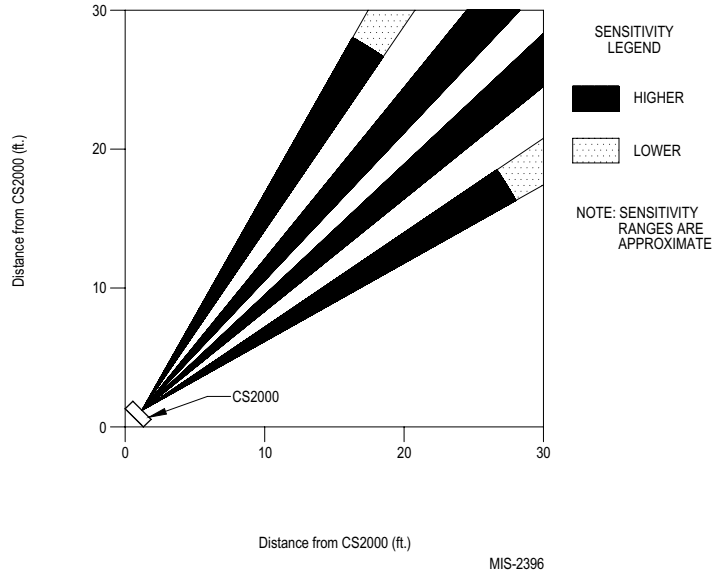

**Side View Of Detection Zone**

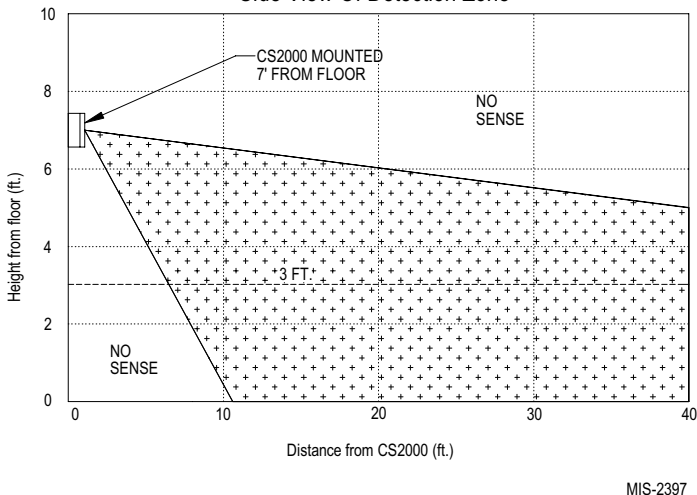

**Note 1:** Coverage ranges are approximate and these diagrams are intended to show general characteristics of the detection zones. Actual detection area can vary from device to device and room to room.

**Note 2:** Do not hang, place or stack any objects between the CS2000A2 sensor/controller and the activity area of the room as they can block the sensor from detecting room occupancy and activity.

**Note 3:** To avoid possible false detections:

- a. Do not hang any mobiles or other objects from the ceiling within 15 feet of the installation position of the CS2000A2 controller.
- b. The bottom of any mobiles or other objects hanging from the ceiling must be at least 1 foot above the installation height of the CS2000A2 controller.

### Energy Controller Corner Mounting Bracket

